



PM-114L  
PM-98L / PM-32L



PA-82 / PA-22  
PM-82 / PM-22



PM-114  
PM-98 / PM-32



PM-70 / PM-12

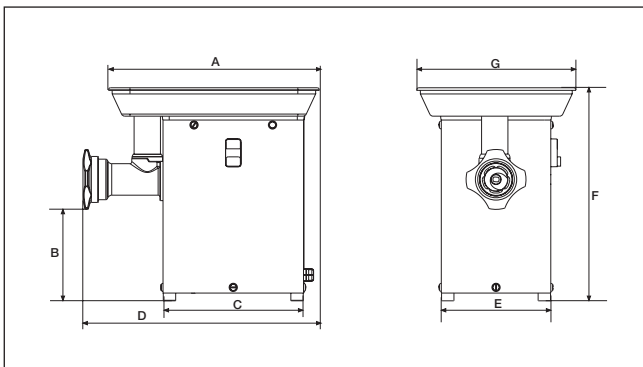

mm	A	B	C	D	E	F	G
PM-70 / PM-12	410	175	270	455	210	410	310
PM-82 / PM-22	500	130	300	545	240	430	350
PA-82 / PA-22	500	130	300	545	240	430	350
PM-98 / PM-32	605 (720*)	120	370	700	280	570	405 (470*)
PM-98L / PM-32L	720 (840*)	540	500	900	410	995	460 (535*)
PM-114	605 (720*)	100	370	750	280	570	405 (470*)
PM-114L	840	520	500	950	410	1010	535

\*Bandeja Gigante / Giant Tray / Reisen-einfüllschale / Tramoggia gigante / Grand Bac.

### PICADORAS DE CARNE

Sistemas de corte UNGER (70, 82, 98 y 114) y ENTERPRISE (12, 22, 32).

Con grupo boca exterior : evita la transmisión de calor a la carne y es muy fácil de desmontar para su limpieza e higiene.

Transmisiones por engranajes bañados en aceite muy silenciosas (PM-70/12 transmisión por correa dentada).

Pican toda clase de carnes, blandas o duras.

Salida uniforme y continua de la carne por la boca.

Construcción: totalmente en acero inox (PA-82/22: boca en aluminio).

OPCIONES:

Bandejas Gigantes de gran capacidad (ver cuadro arriba). Protector placas (para placas con agujeros de  $\geq 8$ mm).

### MEAT MINCERS/ MEAT GRINDERS

Cutting Systems: UNGER (70, 82, 98, 114) and ENTERPRISE (12, 22, 32).

With external mincing head assembly to prevent heat transfer from the motor. Easy to dismantle for cleaning and hygiene.

Transmission: gear driven in an oil bath for silent running (PM-70/12 is driven by means of a toothed belt).

Mincing all kind of meats. The mince produced is of an even and uniform texture.

Construction: Completely in stainless steel ( PA-82/22: mincing head in aluminium).

OPTIONS:

Giant tray (see above table). Finger Guard when using plates of 8mm or larger in all models.

### FLEISCHWÖLFE

Schneidsystem UNGER (70, 82, 98 und 114) und ENTERPRISE (12, 22, 32).

Aufgesetztes Mundstück: verhindert Wärmeübertragung und ist zur Reinigung einfach abnehmbar.

In Öl gelagerte Übersetzung. Sehr leise (PM-70/12 mit Keilrie-men-Übertragung) Für alle Fleischarten geeignet (weich u. hart).

Erzielt eine gleichförmige Fleischmasse.

Konstruktion: komplett aus rostfreiem Edelstahl (PA-82/22: aus Aluminium. Körper und Schnecke aus Edelstahl).

OPTIONEN:

Riesen-Einfüllschale mit grosser Kapazität (s. Tabelle) Schutz für Scheiben (bei Loch-scheiben  $> 8$  mm).

### TRITACARNI

Sistemi di taglio UNGER (70, 82, 98 e 114) e ENTERPRISE (12, 22, 32).

Con gruppo bocca esterna: evita la trasmissione di calore alla carne ed è molto facile da smontare per la sua pulizia e igiene.

Trasmissione ad ingranaggi bagnati in olio molto silenziosa (PM-70/12 trasmissione per nastro dentato).

Trita tutti i generi di carne, morbide e dure.

Uscita della massa per la bocca uniforme e continua.

Costruzione: in acciaio inox. (PA-82/22: bocca in alluminio)

OPZIONI:

Vassoi Giganti (vedi quadro in alto). Protettore piastre (per piastre dal foro di  $\geq 8$ mm).

### HACHOIRS

Système de coupe UNGER (70, 82, 98, 114) et ENTERPRISE (12, 22, 32).

Avec groupe bouche extérieure : évite la transmission de chaleur à la viande et est très facile à démonter pour son nettoyage et hygiène.

Entraînement a pignon en bain d'huile très silencieux (PM-70/12 par courroie dentée).

Hache toutes sortes de viandes, tendres et dures.

Sortie uniforme et continue de la masse par la bouche.

Construction en acier inox. (PA-82/22 groupe bouche en aluminium).

OPTIONS:

Grand bac (voir tableau en haut). Protecteur plaques (d'utilisation obligatoire pour plaques de  $\geq 8$ mm).

ENTERPRISE (SC*)	UNGER (SC*)	UNGER (DC*)	UNGER (TC*)
PM-12	PM-70		
PM-22	PM-82		
PA-22	PA-82		
PM-32	PM-98 / PM-98L		
PM-32L	PM-114 / PM-114L		



ENTERPRISE



UNGER

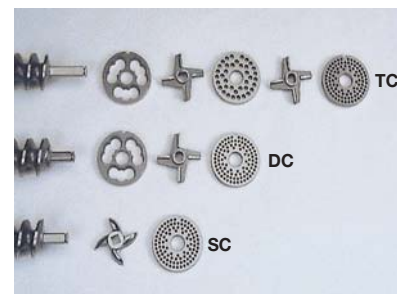

UNGER

SC\* = Simple Corte / Simple Cut / Einfach-Schnitt / Taglio semplice / Simple Coupe

DC\* = Doble Corte / Double Cut / Doppel-Schnitt / Doppio Taglio / Double Coupe

TC\* = Triple Corte / Triple Cut / Dreifach-Schnitt / Triplo Taglio / Triple Coupe

### CARACTERÍSTICAS TÉCNICAS - TECHNICAL DATA - TECHNISCHE DATEN - CARACTERISTICHE TECNICHE - CARACTERISTIQUES TECHNIQUES

Motores - Motors - Motoren - Motore - Moteurs:

III, 230-400V, 50 Hz

II, 230V, 50 Hz

HP / kW

HP / kW

0,75-1 / 0,55-0,74

0,75-1 / 0,55-0,74

1,5 / 1,1

1,25 / 0,9

1,25 / 0,9

1,25 / 0,9

2-3-5 / 1,5-2,2-3,7

2,5-3 / 1,84-2,21

3-5 / 2,2-3,7

2,5-3 / 1,84-2,21

5 / 3,7

-

5 / 3,7

-

Producción - Yield - Leistung - Produzione - Débit :

Kg / h

Kg

± 170

20

± 300

32

± 300

30

± 700

53

± 700

85

± 1000

74

± 1000

106

Peso Neto - Net Weight - Netto Gewicht - Peso Netto - Poids net:



EQUIPAMIENTOS CARNICOS, S.L.

P.I. "Coll de la Manyà" - Jaume Ferran, s/n.

E-08403 Granollers (Barcelona) SPAIN

www.mainca.com / E-mail: mainca@mainca.com

☎ (+34) 93 849 18 22 - (+34) 93 849 17 54

Fax: (+34) 93 849 71 76